

Scaffolding

Scaffolding is widely used during construction and renovation activities.

In its simplest form, a scaffold is any temporary elevated or suspended work surface used to support workers and/or materials. There are many types of scaffolds, both supported and suspended. Included here are general requirements for all scaffolds, as well as specific requirements for one type each of supported scaffold (tubular welded frame) and suspended scaffold (two-point suspension).

General

1. The footing of scaffolding must be sound and rigid, capable of supporting the weight. Scaffolding must not be placed on unstable objects, such as bricks or blocks.
2. Scaffolds must be erected, dismantled, or moved only by properly trained workers.
3. Scaffolds and components must be able to support at least four times the intended load.
4. Standard guardrails (e.g., handrail and midrail) and toeboards must be provided for all open sides of the scaffolding that are ten (10) feet or more above the surrounding surfaces.
5. To protect against falling objects, screens must be installed between the toeboard and midrail if anyone is required to pass under the scaffolding.
6. Any damaged or weakened component of a scaffold must be repaired or replaced immediately.
7. All planking or platforms must be overlapped a minimum of twelve (12) inches and secured from movement. Scaffold planks shall extend over their end support at least six (6) inches but no more than twelve (12) inches.
8. An access ladder or other safe access must be provided.

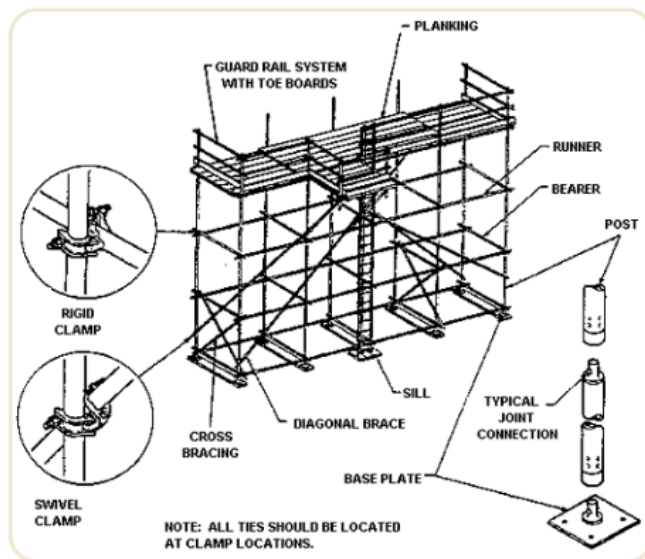

Scaffolds (Tubular Welded Frame)

1. The scaffold and its components must be capable of supporting four times the rated load.
2. Cross-braces of the proper length must be used to ensure that the scaffold will remain plumb and rigid.
3. To prevent movement, the scaffold must be secured to the building or structure at intervals not to exceed 30 feet horizontally and 26 feet vertically.
4. Rolling scaffold must not be used on sloped surfaces.

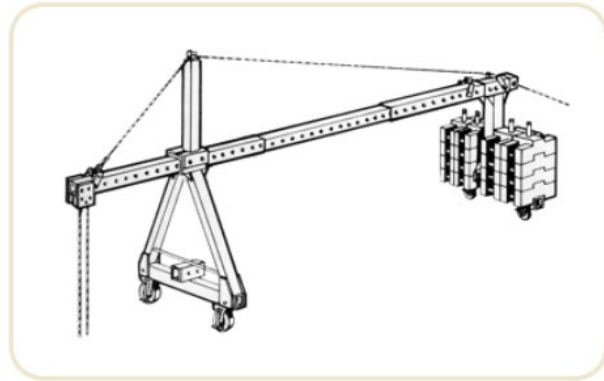

Swinging Scaffolds (Two-Point Suspension)

1. The platform of a two-point suspension scaffold must not be more than 36 inches wide unless designed by a qualified person, and must be surrounded with a standard guardrail and toeboard.
2. Ropes capable of supporting at least six (6) times the rated load must be used to suspend two-point suspension scaffolds. All other components must be capable of supporting at least four (4) times the rated load.
3. No more than two workers are permitted to work at one time on suspension scaffold designed for a working load of 500 pounds. No more than three workers are permitted to work at one time on suspension scaffolds with a working load of 750 pounds. Each worker must be protected by a personal fall arresting system attached to an independent lifeline. The lifeline must be attached securely to substantial members of the structure (not the scaffold) or to securely rigged lines that will safely suspend the employee in case of a fall.

