

Math 30 – Workshop #1

1. Below is the graph of $y = f(x)$.

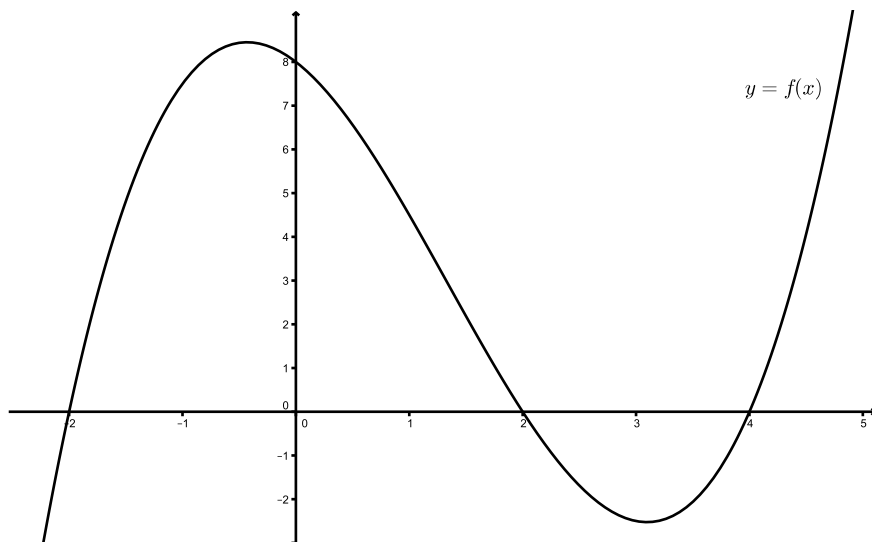

- (a) What does $f(1)$ equal? $f(2)$? $f(0)$?
- (b) For what value(s) of x does $f(x) = 3$?
- (c) For what value(s) of x is $f(x)$ negative?
- (d) For what value(s) of x is $f(x) > 3$?
- (e) For what value(s) of x is $f(x) > f(3)$?

2. Below is the graph of $y = g(x)$.

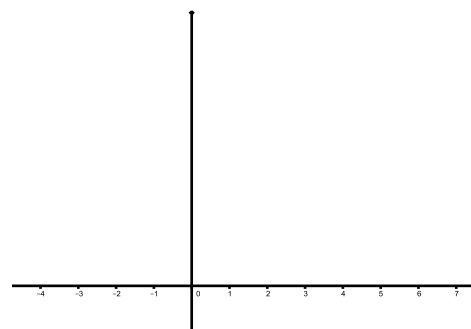
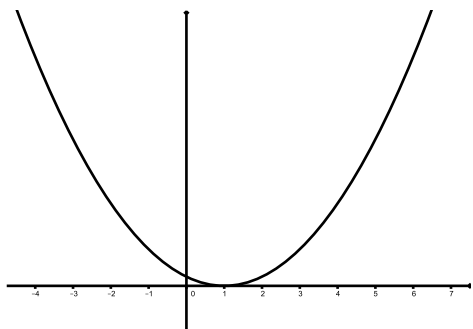

- (a) On the set of axes at the right, plot the points $(x, g(2x))$ when $x = 1$, $x = -1$, $x = 2$, $x = 0$, and $x = 3$.
- (b) Plot additional points, $(x, g(2x))$, if need be, then sketch the graph of $y = g(2x)$ on the axes at the right.
- (c) How does the graph of $y = g(2x)$ compare to the graph of $y = g(x)$?

3. Consider the function $h(x) = x^2 - 3x$.

(a) Find an expression for $h(x + 3)$.

(b) Graph $y = h(x)$ and $y = h(x + 3)$ on your calculator. How do the two graphs compare?

4. A pool, shaped as in the picture below, has a tape measure and a hose hanging down one side. The hose is filling the pool at a rate of 10 ft^3 per minute.

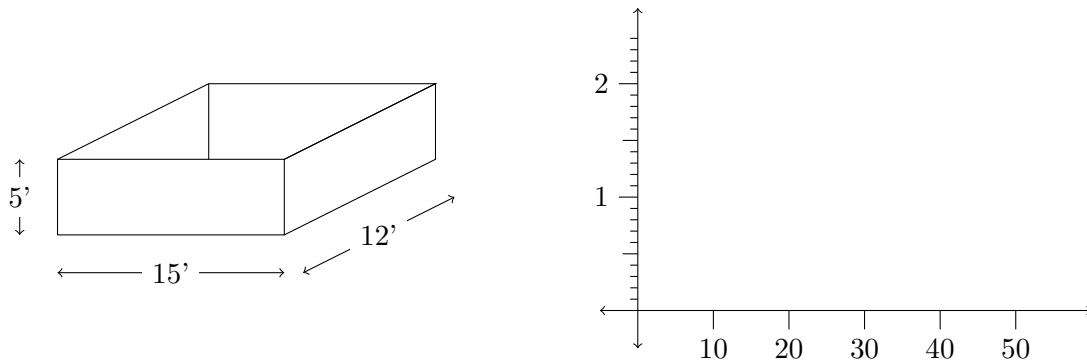

(a) What measurement will the top of the water read on the tape measure after 20 minutes? 30 minutes? 40 minutes?

(b) Let $p(x)$ represent the height of the water after x minutes. Sketch the graph of $y = p(x)$ on the set of axes above.

(c) Suppose instead the pool is 20 feet wide, instead of 15 feet wide. If you graphed the height of the water versus time, you would again get a line. Would this line be more steep or less steep than the line in part 4b? Why?

(d) Suppose we now have a pool that is shaped as below. Sketch the graph of the height of the water versus time?

(You will not be able to graph it exactly since there are no measurements, but you should be able to determine the general shape of the graph.)

tape measure
and hose

