

Robotic Dog (MEGABYTE)

Kristian Ornelas, Alfred Martinez III, Marcus Huston, Edgar Granados

Fall 2019-Spring 2020

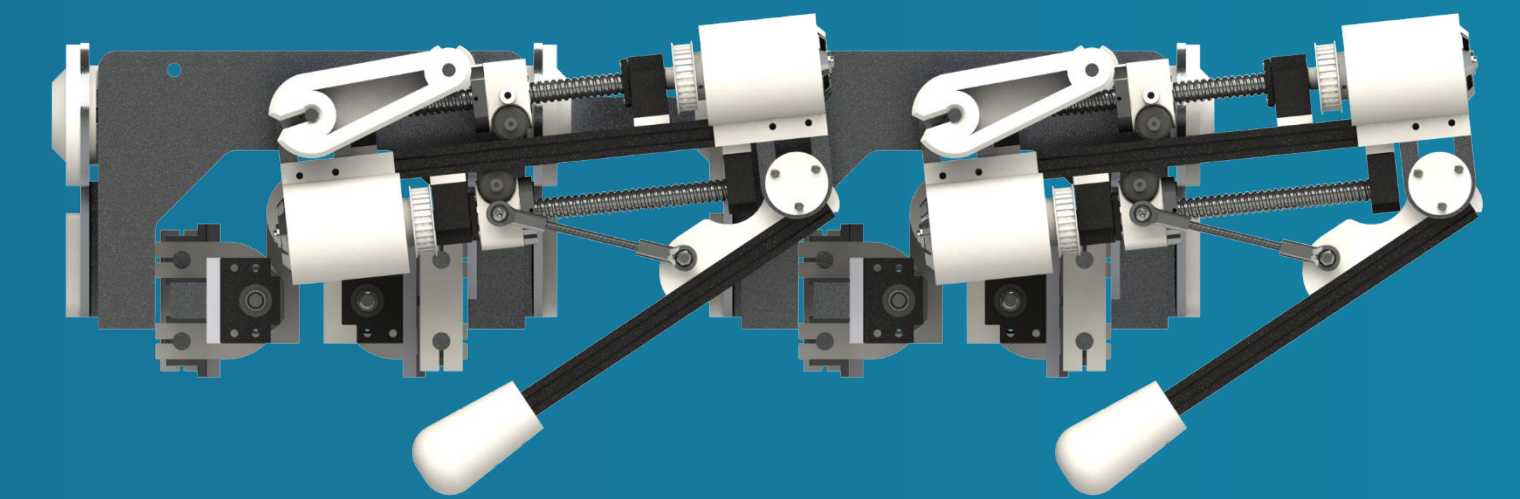

Problem Statement

Design the power and control systems for a robotic quadruped that will be able to operate semi-autonomously and dynamically with its environment through the use of visual, inertial, and contact sensors.

DYNAMIC LOCOMOTION

Our Quadrupedal Robot will utilize 3 degrees of freedom in each of its legs, mimicking a dog. To be fully operational, the robot must be able to traverse uneven terrain, walk at a variable pace, and self balance in real time. Each of these is therefore being developed through the use of PID Control, Torque Control, and Inverse Kinematics.

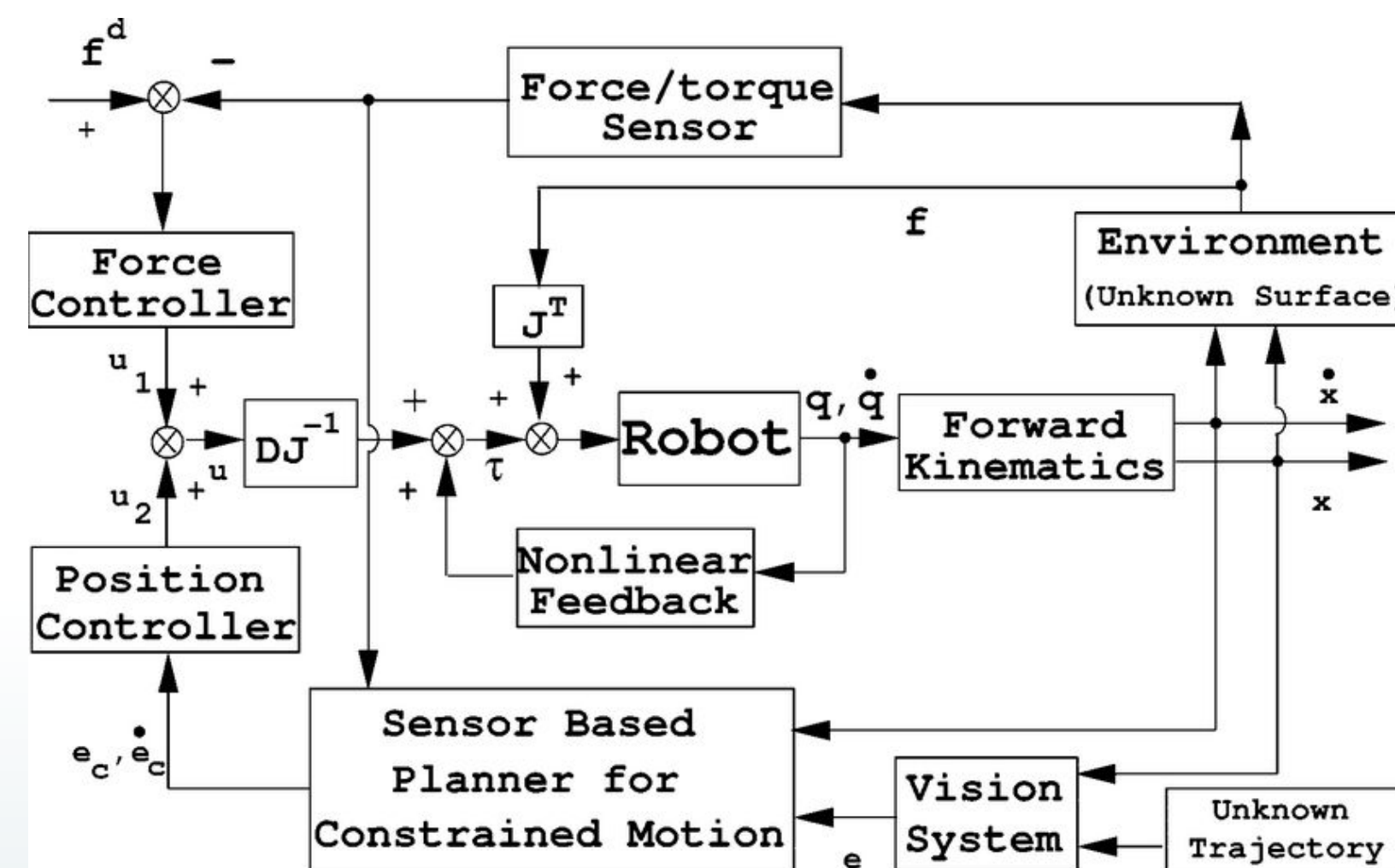

Background/Introduction

One of the most common applications of quadruped robots is for search and rescue. Their articulation and maneuverability allows them to traverse uneven terrain, avoid obstacles, and correct for external forces. This gives them an advantage over traditional wheeled vehicles.

VISUAL SENSORS

To interact with its environment the robot will be equipped with a series of cameras and distance sensors. These will be used for path planning and object avoidance by utilizing ROS and OpenCV on an Nvidia Jetson Nano for rapid parallel computing on its CUDA-Core GPU.



Impact on Community

Walking Robots will be vital a variety of applications including:

- Military
- Industrial
- Disaster Relief
- Research

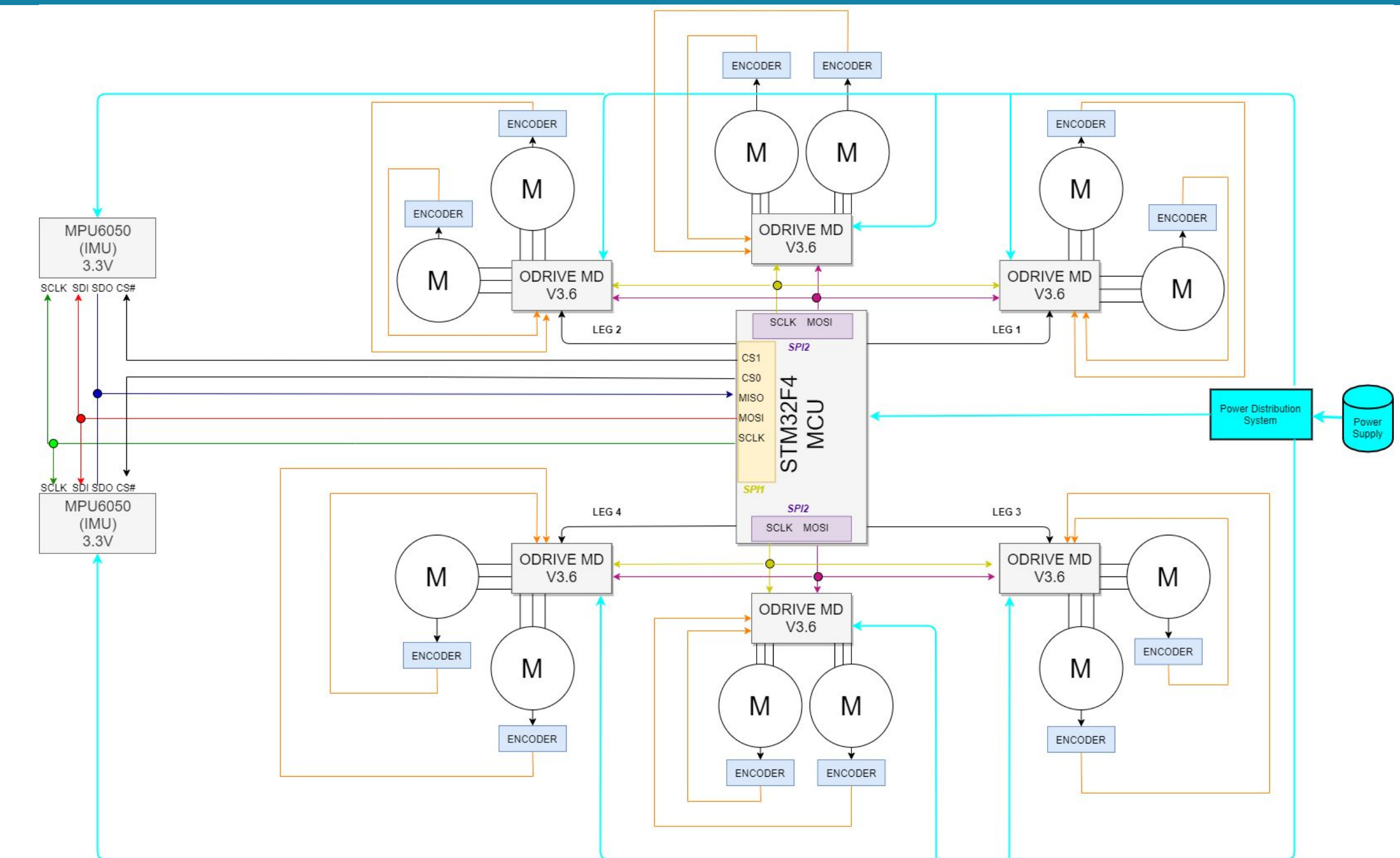

Summary of Work

- Miniature Prototype to develop with STM32 Nucleo as bare-metal Motor Control Board.
- Simulator in V-Rep Software used for prototyping gaits.
- Nvidia Jetson Nano (Ubuntu 18.04) with ROS to operate higher level robot control and learning with webcams.
- Construction and control of one of the large model legs.

SIMULATION

A Robotic Simulation is being used to optimize the walking gaits and reactive patterns that the finalized robot will use. This will also allow the utilization of machine learning further increasing the robots capabilities.

